

- ▶ COTAS DE POSICIONAMIENTO DE LOS MARCOS
- ▶ RACK MOUNTING PLAN
- ▶ COTES DE POSITIONNEMENT DU CADRE
- ▶ COTAS DE POSICIONAMENTO DOS BASTIDORES
- ▶ BEFESTIGUNGSPLAN FÜR MONTAGERAHMEN

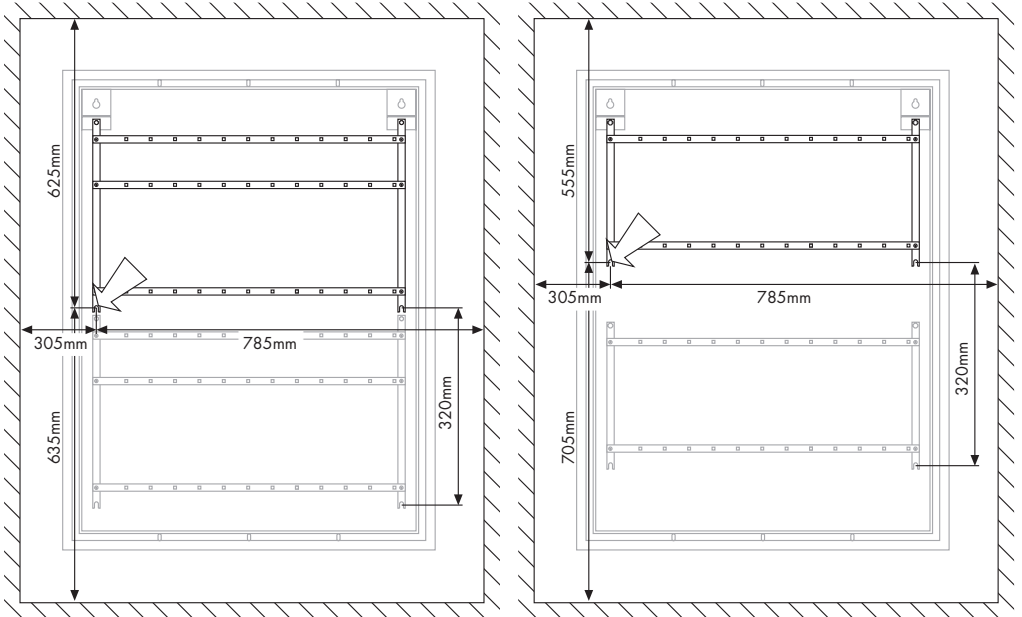

- ▶ COMO FIJAR EL MARCO EN LA PARED
- ▶ HOW TO FIX RACK ON THE WALL
- ▶ COMMENT FIXER LE CADRE DE MONTAGE
- ▶ COMO FIXAR O BASTIDOR NA PAREDE
- ▶ WANDBEFESTIGUNG DES MONTAGESCHRANKES

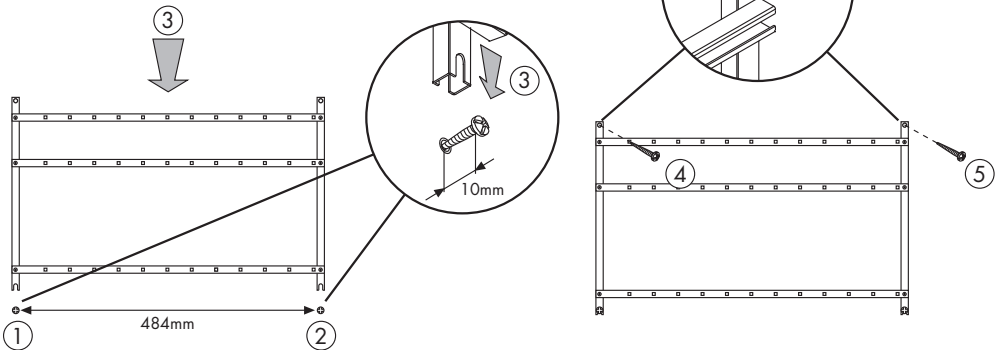

- ▶ COMO FIJAR EL COFRE EN LA PARED
- ▶ HOW TO FIX CABINET ON THE WALL
- ▶ COMMENT FIXER LE COFFRET SUR LE MUR
- ▶ COMO FIXAR O ARMARIO NA PAREDE
- ▶ WANDBEFESTIGUNG DES MONTAGESCHRANKES

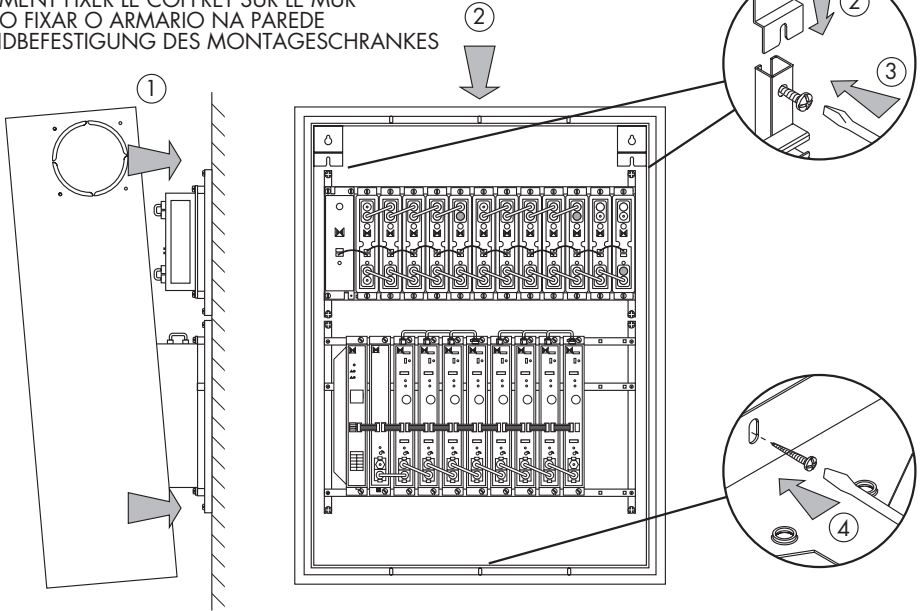

- ▶ COMO CERRAR EL COFRE
- ▶ HOW TO CLOSE CABINET DOOR
- ▶ COMMENT FERMER LE COFFRET
- ▶ COMO FECHAR O ARMARIO
- ▶ SCHLIESSEN DER TUR DES MONTAGESCHRANKES

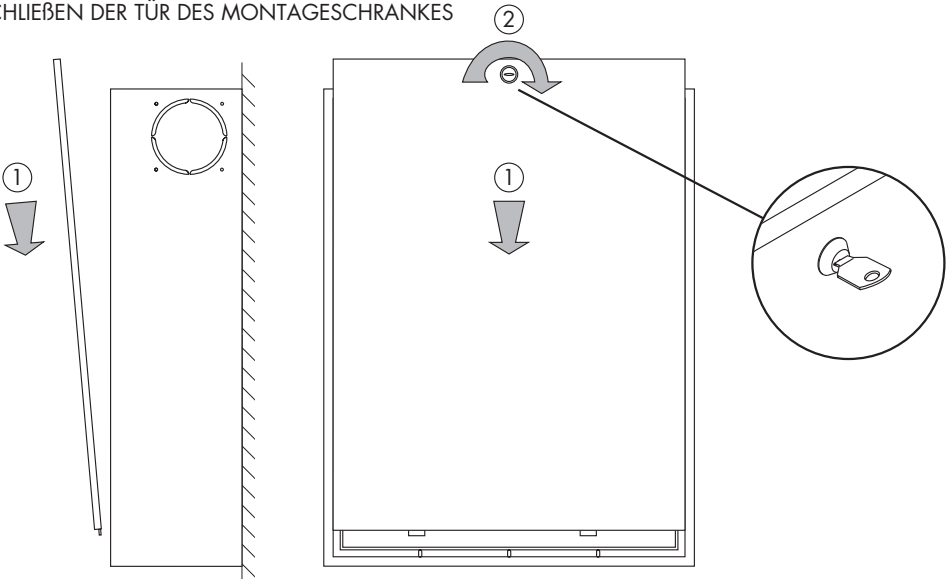

ALCAD, S.A.
 Tel. 943 63 96 60
 Fax 943 63 92 66
 Int. Tel. +34 - 943 63 96 60
 info@alcad.net
 Apdo. 455 - C/GABIRIA, 15
 20305 IRUN - Spain

Tel. 21 - 716 10 36
 Fax 21 - 716 41 09
 R. Dr. JOAQUIM MANSO, 12A
 1500 LISBOA - Portugal

Tel. 00 34 - 943 63 96 60
 Fax 00 34 - 943 63 92 66
 B.P. 284
 64702 HENDAYE - France

Tel. 080 38 - 91 73
 Fax 080 38 - 91 74
 HOLZHAUSEN, 11
 83556 GRIESSTATT - Deutschland



ISO 9001

